

Formal Assessment

English
Formal Assessment
Grade 1
Term 2
Learner:

	Total
Listening and Speaking	/9
Reading	/16
Overall result	/25

<u>Rating Code</u>	<u>Description of competence</u>	<u>Percentage</u>
7	Outstanding achievement	80-100%
6	Meritorious achievement	70-79%
5	Substantial achievement	60-69%
4	Adequate achievement	50-59%
3	Moderate achievement	40-49%
2	Elementary achievement	30-39%
1	Not achieved	0-29%

Teacher's remark: _____

Intervention: _____

The tortoise and the hare.

Once upon a time, a hare was walking around the forest looking for something to do, when he came across a tortoise. The hare started teasing the tortoise because he was slow. The hare said, "Slow coach, slow coach! I bet if we had a race I would beat you." The tortoise thought about it for a moment and then said, "You're on. I will race you through the forest. Just remember, you may not necessarily win just because you're faster than me." The hare then said, "You're crazy!! Of course I will win. I can run like the wind."

And so the tortoise and the hare got ready to start the race at the starting line. The wise old owl said from his tree branch, "On your marks, get set and GO!" And off they went, the tortoise moved along slowly but steadily and the hare whizzed out in front and was away in a flash. The hare got half way through the forest when he thought, "I'm miles ahead of the tortoise. I'm just going to have a little rest and then afterwards I'll continue. I know I'll still be in front because that silly tortoise is so slow." And so the hare lay down and fell fast asleep. A little while later the tortoise came plodding along and walked right past the hare while he was fast asleep. The tortoise had overtaken the hare.

After a while the hare eventually woke up, looked around and said, "Just as I thought, no sign of the tortoise. I'm going to win

the race because that tortoise is a slow coach.” And away he raced through the forest. The hare was just coming around the last corner towards the finish line, when he heard all the forest animals cheering. He got so excited because he thought they were all cheering for him. As the hare came around the corner he saw that the forest animals were not cheering for him, but they were cheering for the tortoise. The tortoise had come first. He had beaten the hare and won the race. The hare could not believe his eyes. He couldn’t understand how the tortoise had won the race. The tortoise came over to the hare and said, “I won the race because I never gave up. Slow and steady won the race.” The hare learnt a very important lesson that day.

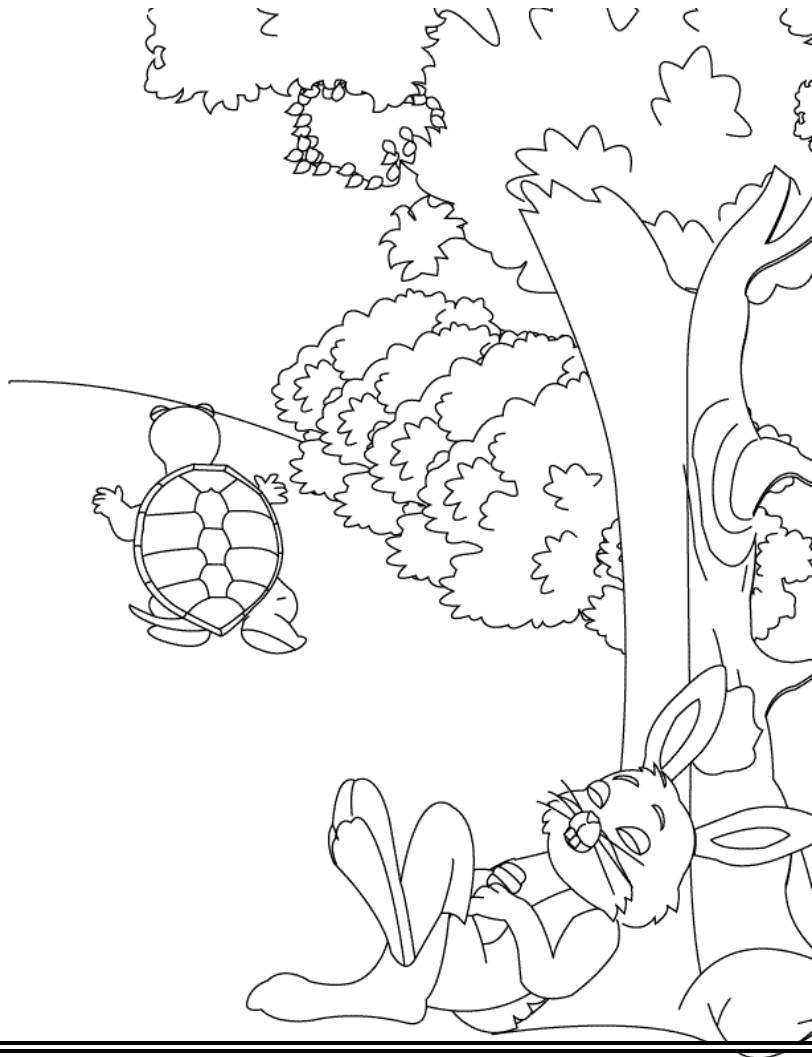

Listening and speaking	Code
Listens to stories with interest, drawing a picture to show understanding.	/4,5

Pretend that you are in the race and draw a picture about the story
“The tortoise and the hare.”

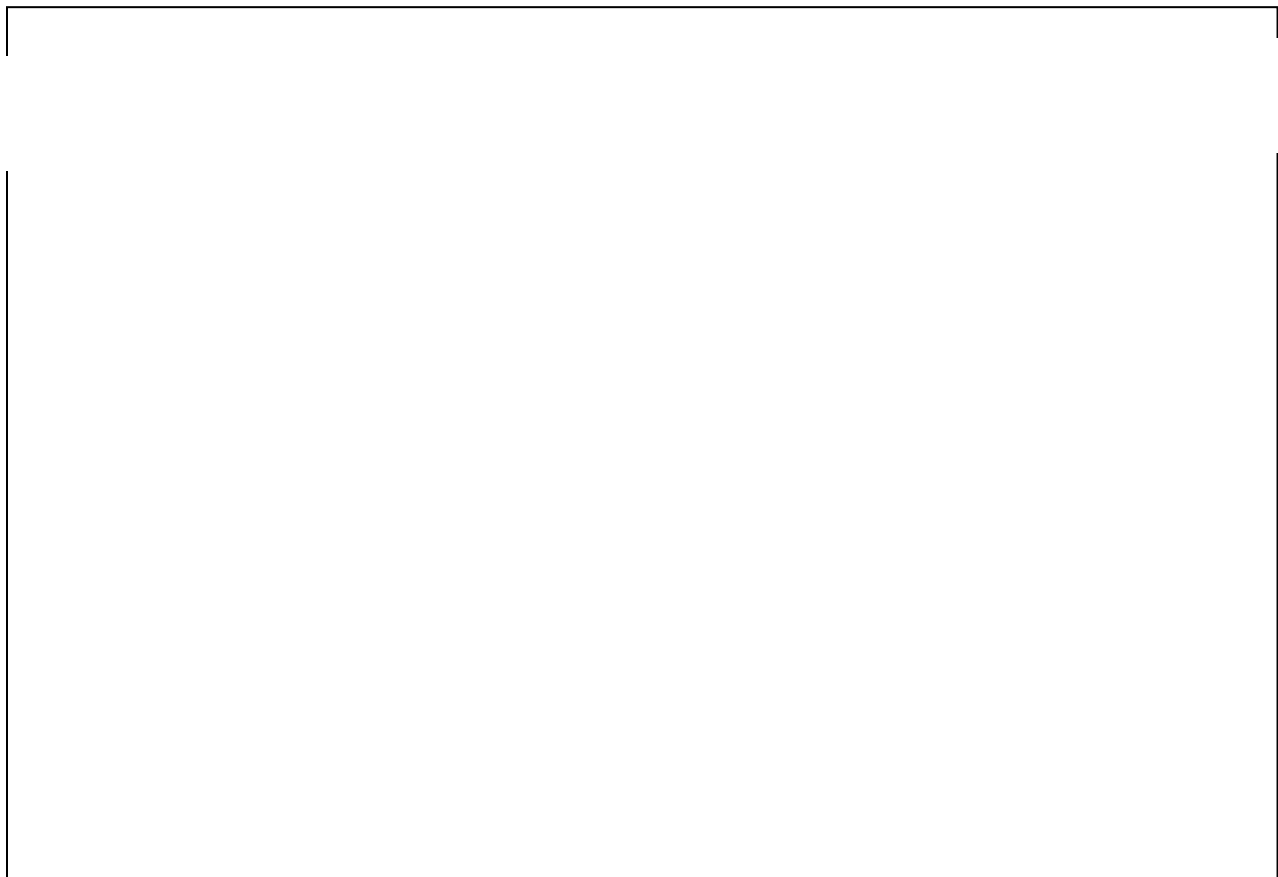

Listens to the story without interrupting.	/1
--	----

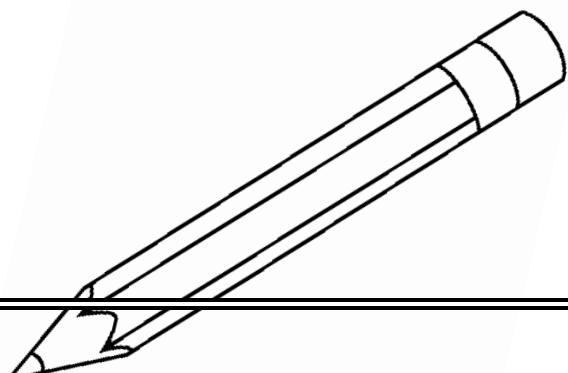

Draws a picture that is relevant to the story.	/2
The picture is neat and detailed.	/1.5

Listening and speaking	Code
Answers closed and open ended questions.	/2

1. Identify the two main animals in the story? (1)

2. Describe how you would feel if you were the tortoise and were being teased? (1)

Listening and speaking	Code
Listens to stories and identifies main ideas.	/2,5

1. Where does the race take place? Summarise it below. (1)

2. Can you tell me how the tortoise is different to the hare? (1,5)

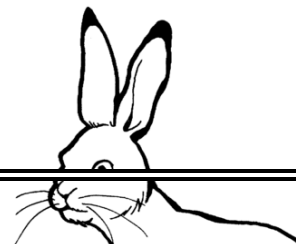

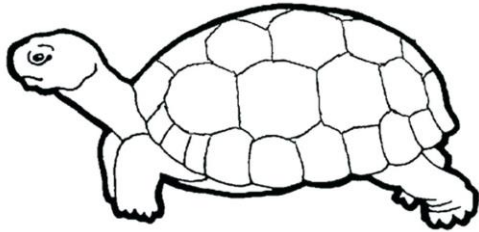

Reading		Code
Answers a wide variety of types of questions based on texts read including high order type questions.		/2

1. In your opinion, what is the moral of the story? (1)

2. What did you think when the tortoise won? (1)

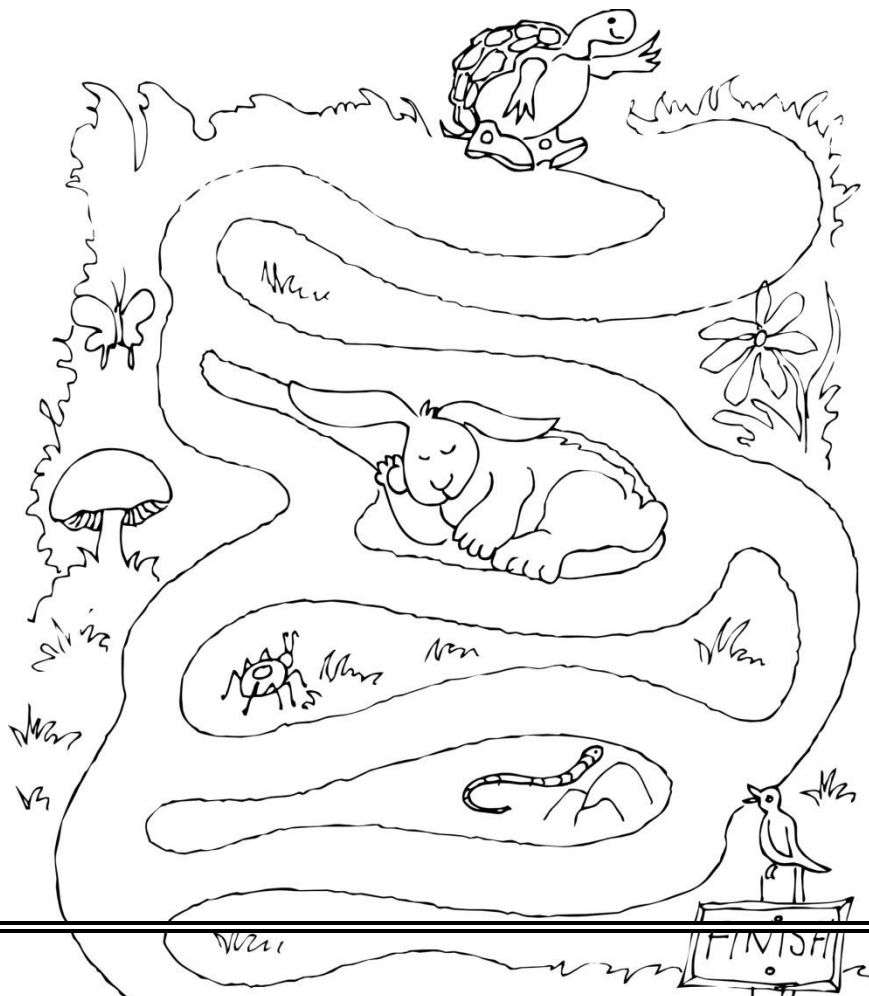

Reading	Code
Interprets pictures to make up own story by “reading” the pictures.	/10

Look at the pictures and tell the story.

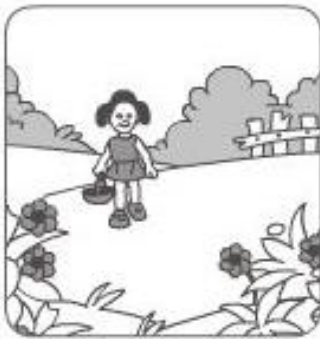



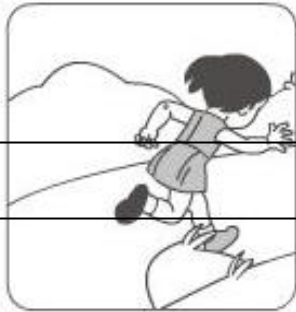

Reading	Code
Uses clues and pictures in the text for understanding.	/4

Number the pictures to show the correct sequence.

